

Inoculant

Applicator guide



For on-farm applications

In our efforts to supply our customers with straightforward and factual information, we have put together this Inoculant Applicator Guide to help you find the right application system to apply your inoculants.

1. Liquid and wettable powder applicators

Applicator
Liquid Seed Treater

Description

- 12V DC pump system
- Metering valve adjusts the flow rate for varied products and application rates
 - Mounts on gravity wagon or grain cart
- Accurately meters the treatment as the seed goes into the auger or conveyor
 - 50' wiring harness with 3-position switch
 - "Hands Free" switch turns the treater on/off automatically



Manufacturer
Enviropac, Inc.

Contact
Enviropac, Inc.
PO Box 229
Compton, IL
Toll Free: 1-800-752-1414
Fax: 815-497-2300
www.enviropacinc.com

Suggested retail price*
\$430 (USD)

Applicator
"The Handler" VL Seed Treatment Pumping System

Description

- Free standing unit with high capacity triple diaphragm pump (3.3 gpm open flow)
 - Continuous agitation
 - 12V DC or 110V AC electric drive
 - Available in 13-gallon tank only
 - All units complete with auger mounted spray assembly
- Suitable as pumping system for "Total Coat" high throughput applicator and other manufacturers application equipment



Manufacturer
Focus Industries Inc.

Contact
Focus Industries
17A Rayborn Crescent
St. Albert, AB T8N 5C3
Tel: 780-459-5599
Fax: 780-459-4401
Toll Free: 1-866-688-2657
Email: info@focusindustries.ca
www.focusindustries.ca

Suggested retail price*
\$1,234 to \$1,452 (CDN)

Applicator
G3 Calibrated System

Description

- Mounts on calibrated transfer auger or elevated hopper discharge
- Transforms seed to air suspended curtain for uniform kernel dosage rates
- Pre-calibrated charts allow for precise application (included)
- Various package systems available (30-litre & 120-litre tanks)



Manufacturer
Graham Seed Treating Systems Ltd.

Contact
Graham Seed Treating Systems Ltd.
Olds, AB
Toll Free: 1-866-556-2846
Fax: 403-556-6604
www.seedtreating.com

Suggested retail price*
Complete systems starting at
\$4,754 (CDN)

Applicator
P1AS Seed Treating System

Description

- 30-litre tank allows continuous treating from 10-litre jugs
- Includes mount straps, discharge valve and filter, 110V AC or 12V DC pump, and A4S auger applicator kit. The A4S kit contains an A4 chemical applicator unit and a seed flow control kit for consistent seed flow delivery
- Mounts on 6" to 8" augers for one step treating/unloading seed

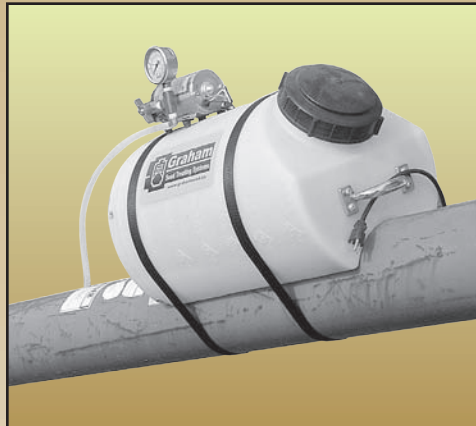

Manufacturer
Graham Seed Treating Systems Ltd.

Contact
Graham Seed Treating Systems Ltd.
Olds, AB
Toll Free: 1-866-556-2846
Fax: 403-556-6604
www.seedtreating.com

Suggested retail price*
Start at \$990 (CDN)

Applicator
P6TS Field Treating System

Description

- Mounts on air seeder or nurse truck, applies into loading auger
- 12V DC powered pump delivery from 30-litre bulk tank
- Applies product through calibrated hollow cone nozzle (included)
- Pre-calibrated charts supplied to provide accurate application rates



Manufacturer
Graham Seed Treating Systems Ltd.

Contact
Graham Seed Treating Systems Ltd.
Olds, AB
Toll Free: 1-866-556-2846
Fax: 403-556-6604
www.seedtreating.com

Suggested retail price*
Start at \$1,195 (CDN)

Applicator

Soybean Inoculator Applicator

Description

- 3.8 gpm 110V AC pump
- Available in 15 or 30-gallon cone bottom tanks
 - Magnetic nozzle holder
- Stand has wheels for easy maneuverability
 - Custom units available



Manufacturer

Horvick Inc.

Contact

Tim Pederson
Horvick Inc.
4350 48th Ave N
Fargo, ND 58102
Toll Free: 1-800-373-4084
Email: tim.pederson@horvick.com
www.horvick.com

Suggested retail price*

Available upon request

Applicator

Classic Seed Treater

Description

- Gravity flow-metered by in-line hose valve (2 valve system – 1 on/off, 1 flow rate)
- Includes 2 ratchet straps for mounting to auger
 - Large (35-litre) tank
- Large 6" cap makes mixing and agitating simple

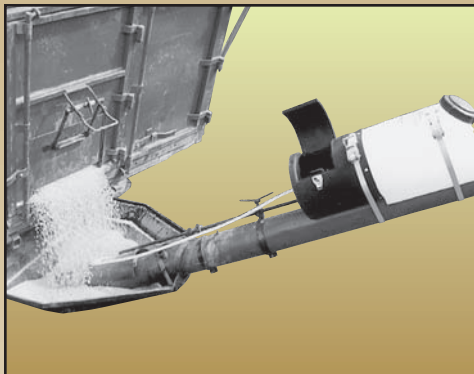

Manufacturer

Lockhart Industries Ltd.

Contact

Lockhart Industries Ltd.
Camrose, AB
Toll Free: 1-888-545-1228
Email: info@lockhart-industries.com
www.lockhart-industries.com

Suggested retail price*

\$315 (CDN)

Available through UFA, Co-op, Flaman and most farm supply stores.

Applicator

NRC Seed Treater

Description

- Combines seed treater and auger-hopper into one easy to use implement
- Fully adjustable, mounted on wheels and fitted with handles make it easy to move
- Fully adjustable pump, interchangeable nozzles provides accurate metering rate control and complete seed coverage
 - Stainless steel construction
- Available with a 12 volt or 110 volt pump

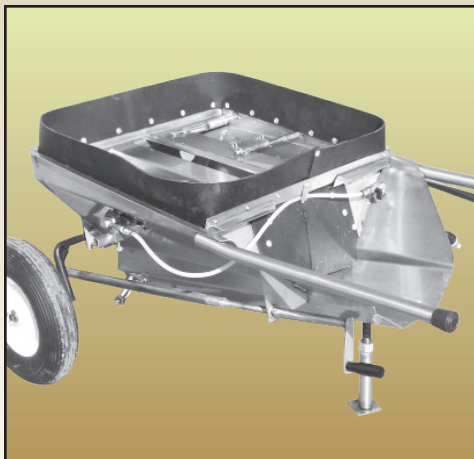

Manufacturer

Dave Waldner

Contact

Dave Waldner
New Rockport Colony
Tel: 403-315-3412

Distributed by all WCDN Viterra retail locations.

Suggested retail price*

\$3,095 (CDN)

2. Liquid, peat slurries, and wettable powder applicators

Applicator

ADVANTAGE Inoculator & Seed Treater

Description

- New sizes: 40-litre and 90-litre spherical tanks with metal cage and carrying handles
- Complete cleanout with rounded bottom
 - Continuous agitation
 - Compressed air delivery system (air tank not included)
- Precise metering with quick disconnect ½ inch SMC fittings



Manufacturer

Spray Advantage

Contact

Farmagro Sales Ltd.
Raymore, SK
Tel: 306-746-4484
Fax: 306-746-4497
Email: agscocanada@sasktel.net

Suggested retail price*

40 litre - \$890 (CDN)

90 litre - \$950 (CDN)

Applicator

“Total Coat” Seed Treatment Applicator

Description

- High throughput (up to 20 MT/hr) ladder-style applicator with dual spray nozzles (can be modified for sequential application of 2 products)
- Suitable for cereals, pulses, and beans
 - Fiberglass construction
- Mounts on auger or conveyor discharge
 - Large orifice nozzles are required for peat slurries
 - Requires a pumping delivery system (not included)



Manufacturer

Focus Industries Inc.

Contact

Focus Industries
17A Rayborn Crescent
St. Albert, AB T8N 5C3
Tel: 780-459-5599
Fax: 780-459-4401
Toll Free: 1-866-688-2657
Email: info@focusindustries.ca
www.focusindustries.ca

Suggested retail price*

\$469 (CDN)

Applicator

DoAll Seed Treater

Description

- Large tank (liquid capacity 25 litres)
 - Hydraulically driven agitator
 - Ball valve metering device
- Mounts easy in any position to suit auger mounting configuration
 - Protective metal screen

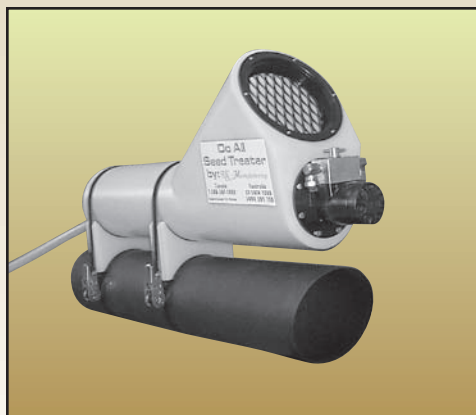

Manufacturer

R.K. Manufacturing Inc.

Contact

R.K. Manufacturing Inc.
Cabri, SK
Tel: 306-587-2841
Email: rkaake@sasktel.net

Suggested retail price*

\$549 (CDN) Treater only
Motor and valve available
for an additional charge

Applicator

"The Handler" H.D. Seed Treatment Pumping System

Description

- Free standing unit with high capacity double diaphragm pump (6 gpm at 50 psi)
 - Continuous agitation. 1hp 110/220V AC electric motor, gas engine or hydraulic driven
- Available in single or twin 13 or 60-gallon tanks (twin tank system by special order only – call for pricing)
- Suitable as pumping system for "Total Coat" high throughput applicator, auger-mounted spray assembly and other manufacturers application equipment
- Includes fittings to draw product directly from bulk containers
 - Designed to thoroughly mix high viscosity products such as polymers and peat-based slurries



Manufacturer

Focus Industries Inc.

Contact

Focus Industries
17A Rayborn Crescent
St. Albert, AB T8N 5C3
Tel: 780-459-5599
Fax: 780-459-4401
Toll Free: 1-866-688-2657
Email: info@focusindustries.ca
www.focusindustries.ca

Suggested retail price*

\$2,842 to \$3,442 (CDN)
depending on pump and tank combination

3. Peat slurry applicators

Applicator

Peat Inoculant Pump Assembly

Description

- Slurry pump applicator for peat inoculants
- 110V AC sewage effluent pump (included)
 - Large barrel required (not included)

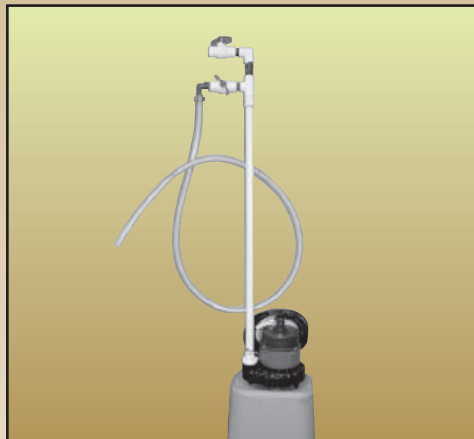

Manufacturer

Anderson Pump House Ltd.

Contact

Brad Stensrud
9802 Thatcher Ave
PO Box 1418
North Battleford, SK
Tel: 306-937-7741
Fax: 306-937-3766
Email: info@andersonpumphouse.com

Suggested retail price*

\$399 (CDN)

Applicator

Auto Heater Fan Mixer

Description

- Uses a squirrel cage fan from a vehicle heater mounted onto a threaded rod
- Attach to an electric drill and use to stir peat slurries
- Use the watering can to pour onto seed while augering



Manufacturer

None

Contact

Novozymes Biologicals
Tel: 1-888-744-5662
Saskatoon, SK

Suggested retail price

Assemble components yourself

4. Dry peat applicators

Applicator

Dry Inoculator/Seed Treater

Description

- 12V DC motor & gearbox system
- Mounts on gravity wagon or grain cart
- Accurately meters the treatment onto the seed as the seed goes into the auger or conveyor
- 50' wiring harness with 3-position switch
 - "Hands Free" switch turns the treater on/off automatically
- Also meters talc or graphite



Manufacturer

Enviropac, Inc.

Contact

Enviropac, Inc.
Compton, IL
Toll Free: 1-800-752-1414
Fax: 815-497-2300
www.enviropacinc.com

Suggested retail price*

\$325 (USD)

* Suggested retail prices shown are from 2009. Please contact the manufacturer for current pricing and specifications.

5. Granular inoculants

Most seeding equipment manufacturers offer a third tank that can be used for the application of granular inoculants. These tanks must have the capability to apply a relatively small amount of granular product per acre. Below are the Equipment Calibration Charts recommended for TagTeam® granular to use as a guide. Contact your local Agriculture Implement dealer for more information on the various tanks available and see calibration charts for other granular inoculants by contacting their manufacturer.

Table 1. Application rates for 36.4 lb bag of TagTeam® pea/lentil and chickpea granular

Row spacing	6.0 in	7.0 in	8.0 in	9.0 in	10.0 in	12.0 in	15.0 in
Application rates	5.5 lb/ac	4.7 lb/ac	4.1 lb/ac	3.6 lb/ac	3.3 lb/ac	2.7 lb/ac	2.2 lb/ac
Area treated per bag	6.6 ac	7.7 ac	8.8 ac	10.1 ac	11.0 ac	13.4 ac	16.5 ac

Table 2. Application rates for 36.4 lb bag of TagTeam® soybean granular

Row spacing	6.0 in	7.0 in	8.0 in	9.0 in	10.0 in	12.0 in	15.0 in	24.0 in	30.0 in
Application rates	7.1 lb/ac	6.2 lb/ac	5.4 lb/ac	4.7 lb/ac	4.3 lb/ac	3.6 lb/ac	2.9 lb/ac	1.8 lb/ac	1.4 lb/ac
Area treated per bag	5.1 ac	5.9 ac	6.8 ac	7.7 ac	8.5 ac	10.2 ac	12.7 ac	20.2 ac	25.9 ac

Note: The bulk density for TagTeam granular averages 43 lb/ft³

This applicator guide is a guideline. Novozymes Biologicals does not warrant the specifications listed here. Purchasers are responsible to verify all specifications, required parts, and pricing with the manufacturer prior to purchasing.

For more information call our toll-free
line at 1-888-744-5662 or visit
www.bioag.novozymes.com.

3935 Thatcher Avenue,
Saskatoon, SK Canada S7R 1A3
1-888-744-5662
www.novozymes.com

Novozymes is the world leader in
bioinnovation. Together with customers
across a broad array of industries we
create tomorrow's industrial biosolutions,
improving our customers' business, and
the use of our planet's resources. Read
more at www.novozymes.com.

novozymes[®]
Rethink Tomorrow